

2017 Chief Executive Election **Summary on Free Postage for Election Mail**

1. Conditions for Free Postage for Election Mails

- (i) A candidate who is validly nominated is permitted to post up to **two** letters to each Election Committee (“EC”) member free of postage.
- (ii) Specifically, the mail must:
 - (a) be posted in Hong Kong;
 - (b) contain materials relating only to the candidature of the candidate at the 2017 Chief Executive election;
 - (c) not exceed 50 grams in weight; and
 - (d) be not larger than 175 mm x 245 mm and not smaller than 90 mm x 140 mm in size.
- (iii) **As a general requirement, a candidate should publish election advertisements in accordance with all applicable laws and the “Guidelines on Election-related Activities in respect of the Chief Executive Election”. The election advertisements sent by a candidate through free postage should not contain any unlawful content.**
- (iv) If the name, logo or pictorial representation of a person or an organisation, as the case may be, is included in the election mail, and the publication is in such a way as to imply or to be likely to cause electors to believe that the candidate has the support of the person or organisation concerned, the candidate should ensure that **prior written consent** has been obtained from the person or organisation concerned.
- (v) The Electoral Affairs Commission (“EAC”) and the Government of the Hong Kong Special Administrative Region (including Hongkong Post and the Registration and Electoral Office (“REO”)) shall not be responsible to the candidate or any third party for the election mail, including but not limited to any liabilities arising from any errors in, omissions from, false or misleading statements in the contents of the election mail. The candidate posting the election mail shall be responsible for the election mail and its contents, and shall indemnify and keep indemnified the EAC and the Government against all liabilities, costs, expenses, actions, proceedings, claims, demands, losses and damages arising out of or in connection with the election mail and its contents.

2. Make-up/Addressing for Free Postage for Election Mails

- (i) The letter may take the form of envelope, lettergramme, card or folder. Items in roll form or enclosed in plastic wrappers are **not acceptable**. Cards and folders must be made of ordinary cardboard or paper not less than 0.25 mm thick, and must be rectangular in shape.
- (ii) When a wrapper is used, it must extend over the full length of the item which it encloses. Envelopes must not be fastened with staples or with paper fasteners with sharp edges or points, but they may be closed by means of an adhesive flap or tape.
- (iii) Envelopes, folders or lettergrammes having an opening large enough to entrap smaller letters are **prohibited**. Unsealed mail item contained in envelopes with ordinary tuck-in flaps may be used up to the following size limits (s.6.3 of the Post Office Guide):

- (a) Not over 90 mm in depth - opening not over 150 mm in length;
- (b) Not over 100 mm in depth - opening not over 140 mm in length;
- (c) Over 100 mm in depth - opening not over 115 mm in length.

If it is necessary for a larger envelope to be used, sender should adopt a pattern having a special kind of flap which can be so adjusted as not to leave a large opening or the packet can be fastened with string which can be easily untied. If metal paper fasteners are used, they must be covered with tape or other protective material to obviate risk of injury to the hands of Hongkong Post staff. Paper clips or staples must not be used.

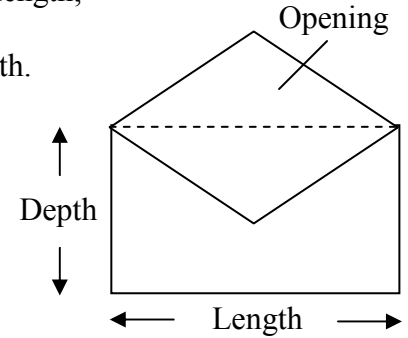

- (iv) Folders, for example, of A4 size with openings should be closed by means of adhesive flap or tape to avoid entrapping smaller letters. All open edges must not be longer than 90 mm in width. Otherwise, adhesive tape should be applied to the midpoints of the open edges to reduce the width. For details, please refer to the illustration in Appendix I.
- (v) The front (address) side of the envelope or the address side of the folder (unenveloped mail) must be as follows:
 - (a) Printed with the Chinese characters “選舉郵件” or “選舉廣告” or words “Election Mail” or “Election Advertisement”;
 - (b) An address zone of at least 80 mm long and 30 mm high preferably at the right-hand half or at the centre of the front (address) side for the address of an elector, should be reserved exclusively for the address;
 - (c) If an adhesive label is used, it should not be less than 80 mm long and 30 mm high. The address label should only contain the name and address of an elector and be affixed to the address zone. The whole address zone and address label should be free of advertisement and should appear on the front side of the mail;
 - (d) The address zone and address label should be in white background colour while the characters of the postal address should be in black. Each English character should not be less than 2.5 mm in height and 2 mm in width. Each Chinese character should not be less than 3 mm in height and 3 mm in width. The font size and type style should be the same for all the address lines. There should be a uniform line spacing of not less than 1.5 mm and the lines should not be overlapped; and
 - (e) **Please note that only one address of an elector should be shown on the postage-free election mail. No postage-free election advertisement bearing an address outside Hong Kong will be accepted.**

The layout of the election mail is as follows -

Front Side of an Election Mail

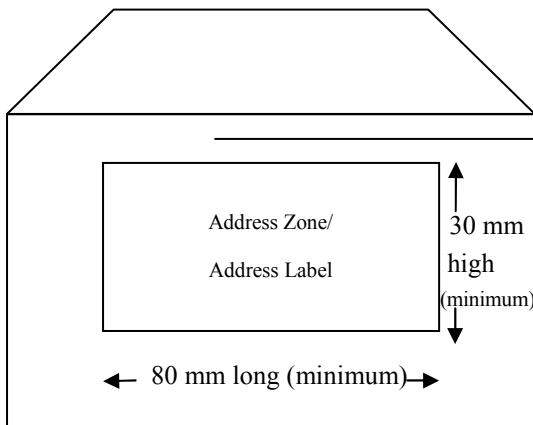

The Chinese characters “選舉郵件” or “選舉廣告” or the words “Election Mail” or “Election Advertisement” must be printed on the front (address) side of the election mail.

Back Side of an Election Mail

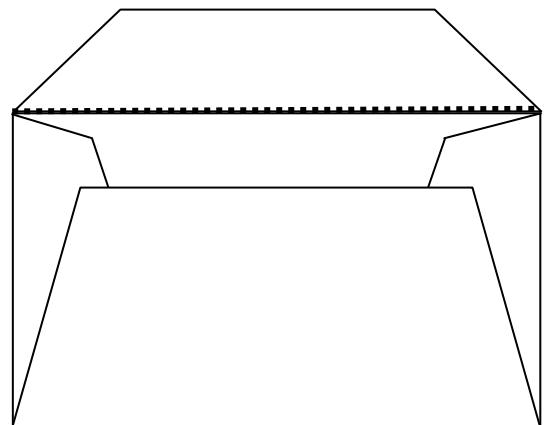

- (vi) The full postal address should be typed or legibly written on the front of the envelope in four rows as follows:

Address in English	Address in Chinese
Name of addressee	收件人姓名
Floor and flat number and name of building	地區名稱
Street number, name of street	街道名稱、門牌編號
Name of district	樓宇名稱、座數及層數

- (vii) Election mail must bear printing details in Chinese or English, which include the name and address of the printer together with the date of printing and the number of copies printed. It applies to all materials reproduced by any method of multiplying copies (e.g. printing machines, duplicators or photocopiers). Some suggested formats are listed as follows:
 - (a) Printed by ABC Printing Works or (b) Printed by own office machine
 XX XZY Street, HK XX XZY Street, HK
 on (date) in (number) copies on (date) in (number) copies
- (viii) Before the publication of the notice of valid nomination(s) in the Gazette, a candidate wishing to exercise his/her right to free postage will be required to furnish the Postmaster General with a security (full postage of the items posted) for the payment of postage in the event that his/her name is not subsequently shown in the above-mentioned notice of valid nomination(s).

3. Posting Arrangements

- (i) Candidates are advised to make their postage-free election mail postings **on or before 21 March 2017 (Tuesday)**. Please note that mail posted after the above deadline will likely fail to reach the addressees before the polling day.
- (ii) Candidates should apply to Hongkong Post for written approval of specimen(s) of their election mail for free postage. Before deciding on the contents of the election mail, candidates should study the requirements governing free postage for election mail carefully. If in doubt, candidates should seek advice from Hongkong Post relating to postal requirements and the REO on other aspects before printing. Candidates should submit the specimen(s) of their election mail to Hongkong Post for approval as early as possible before mass production of their election mails so as to allow sufficient time for revising the specimen(s), if necessary.

- (iii) **At least two clear working days' notice (excluding Saturday, Sunday and public holiday)** must be given to the Manager (Retail Business) of the relevant place as set out in the "List of Post Offices for Election Mails" (Appendix II) before the postings are made. Candidates should submit three unsealed specimens of their election mail, together with a "Notice of Posting of Election Mail" [REO/C/17 (2017CE-E) (SDF)] **in duplicate**, for written approval. **(For example, if the candidate wishes to make his/her posting on 21 March 2017 (Tuesday), the specimens should be submitted on or before 16 March 2017 (Thursday).)** Specimens of election mails will be processed as soon as practicable, but there is no guarantee that the specimens of election mails will necessarily be approved in two working days immediately after their submission.
 - (iv) If the specimens of an election mail submitted by a candidate contain any content in a language other than Chinese and English, the candidate must enclose the Chinese or English translation of such content with the "Notice of Posting of Election Mail" in order to ensure it complies with the requirement in para. 1(ii)(b) above.
 - (v) The postings should be made up in bundles of 50 or 100 each for easy counting. All election mails must be stacked on the same side and arranged in the same order as the address labels/address lists (e.g. by building name or block number) provided by the REO.
 - (vi) When handing in the specimens of the election mail, a candidate must select one of the post offices as set out in the "List of Post Offices for Election Mails" (Appendix II) where he/she intends to make his/her posting. With each posting made at the designated post office, the candidate or his/her election agent must present a signed "Declaration for Posting of Election Mail" [REO/C/18 (2017CE-E) (SF)] **in duplicate**. If a candidate makes posting in more than one batch, the same declaration form must be presented at the same post office office on each occasion.
 - (vii) When making postings, the candidates should provide the manager(s) of the designated post offices with a copy of the election mail for record purpose.
 - (viii) **Please note that undersection 80 of the Electoral Procedure (Chief Executive Election) Regulation (Cap 541J), a candidate sending postage-free mails to EC members in bulk is liable for payment of postage for all the items in that bulk if any item in the bulk does not meet the requirements stated in para.1(ii) above or if the declaration mentioned in para. 3(vi) is false in any particular.**
4. For general enquiries concerning the posting of election mails, please contact officers concerned as listed in Appendix II.

Methods of Folding of Election Mail 郵寄選舉郵件應採用的摺疊方法⁽¹⁾

Figure 1 : Folder of A4 (296mm) size
圖示一：對摺的A4（296毫米）尺寸紙張

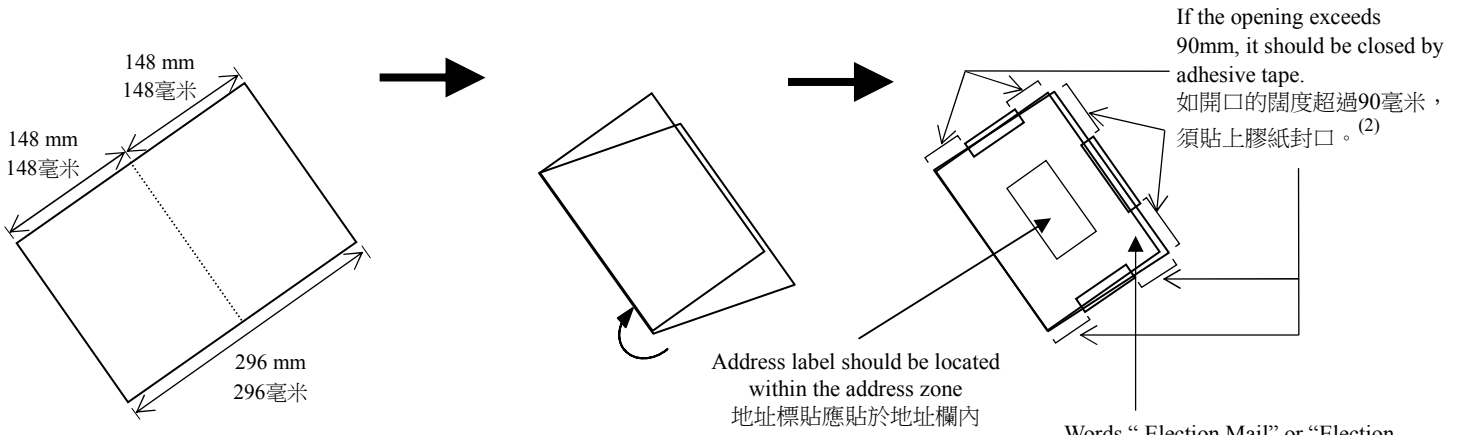

Figure 2 : Folder of A4 (296mm) size with 2 folds
圖示二：兩摺的A4（296毫米）尺寸紙張

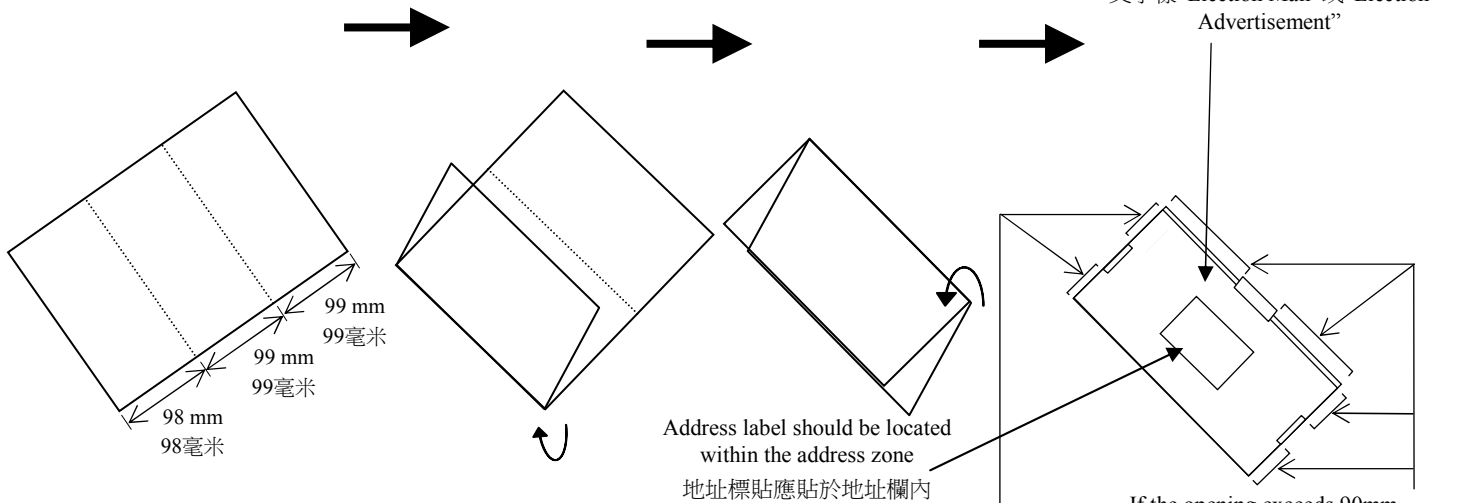
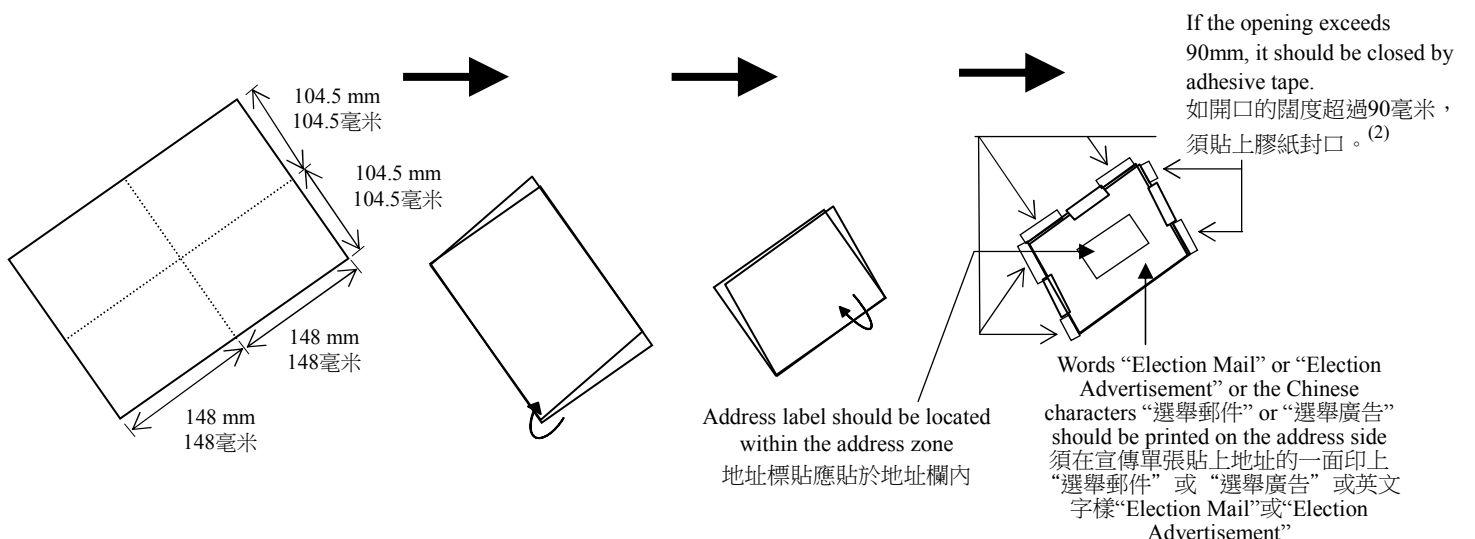

Figure 3 : Folder of A4 (296mm) size with 2 folds
圖示三：兩摺的A4（296毫米）尺寸紙張



Words "Election Mail" or "Election Advertisement" or the Chinese characters "選舉郵件" or "選舉廣告" should be printed on the address side 須在宣傳單張貼上地址的一面印上 "選舉郵件" 或 "選舉廣告" 或英文字樣 "Election Mail" 或 "Election Advertisement"

Words "Election Mail" or "Election Advertisement" or the Chinese characters "選舉郵件" or "選舉廣告" should be printed on the address side 須在宣傳單張貼上地址的一面印上 "選舉郵件" 或 "選舉廣告" 或英文字樣 "Election Mail" 或 "Election Advertisement"

Methods of Folding of Election Mail 郵寄選舉郵件應採用的摺疊方法⁽¹⁾

Figure 4A&4B : Folder of A4 (296mm) size sealed with address label
圖示四A及四B：以地址標貼封口的A4（296毫米）尺寸紙張

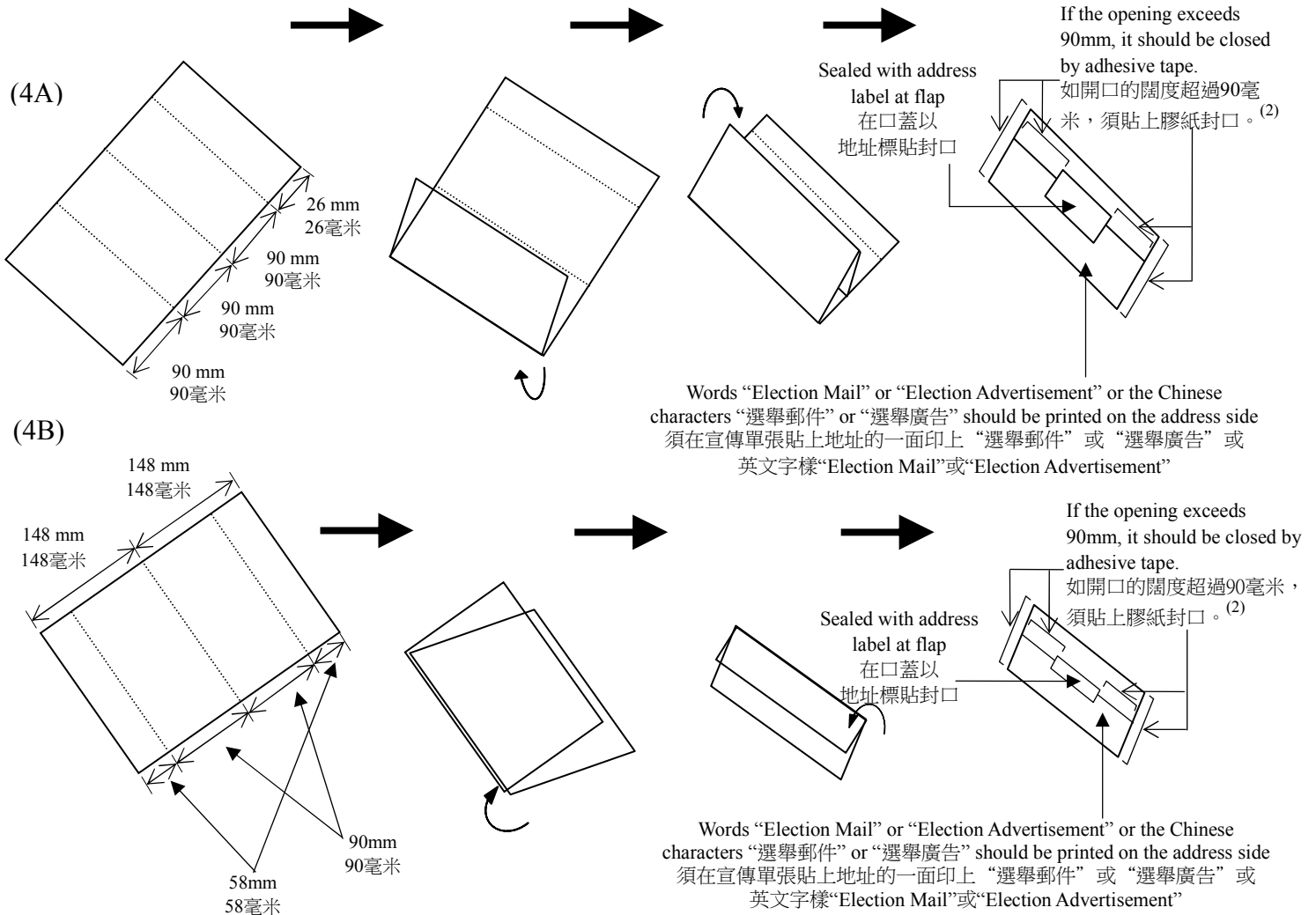
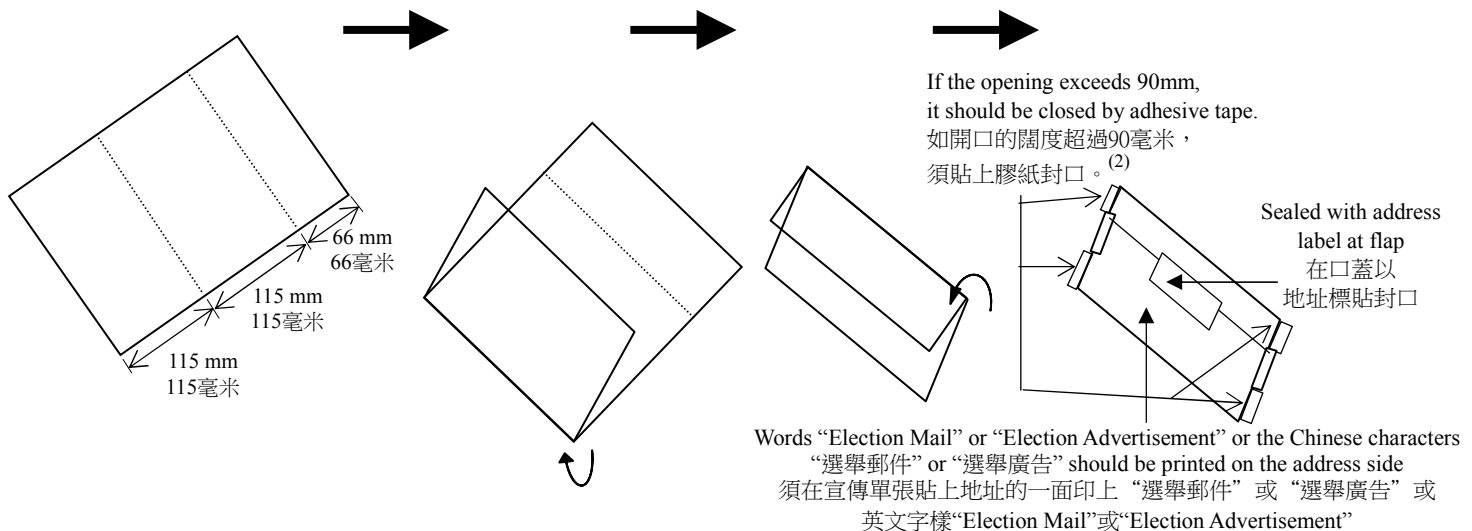

Figure 5 : Folder of A4 (296mm) size sealed with address label
圖示五：以地址標貼封口的A4（296毫米）尺寸紙張



- (1) 無論以任何方法摺疊，所有超過90毫米的開口，必須以膠紙封口。
For any methods of folding, all openings exceeding 90 mm should be closed by adhesive tape.
- (2) 無論郵件的開口是否已經封口，所有開口部份不得超過90毫米，否則須以膠紙封口。
Regardless of whether the opening is closed or not, all openings shall not exceed 90 mm. Otherwise, they must be sealed with adhesive tape.

2017 年行政長官選舉
2017 Chief Executive Election
投寄選舉郵件郵政局一覽表
List of Post Offices for Election Mail

Appendix II
附件二

1. 候選人應於辦公時間（星期六、星期日及公眾假期除外）到以下香港郵政辦事處提交選舉郵件樣本：
 Candidates should submit their specimens of election mail at the following Hongkong Post offices during office hours (excluding Saturday, Sunday and public holiday):

負責人 Responsible Officer	地址 Address	辦公時間 Office Hours	電話 Telephone	傳真 Fax
經理（門市業務／港島西） Manager (Retail Business/Hong Kong West)	中環康樂廣場二號郵政總部一樓 1/F, General Post Office, 2 Connaught Place, Central	9am – 5pm	2921 2417	2501 5930
經理（門市業務／九龍東） Manager (Retail Business/Kowloon East)	九龍灣宏展街 1 號中央郵件中心地下 G/F, Central Mail Centre, 1 Wang Chin Street, Kowloon Bay	9am – 5pm	2908 0372	2868 1442

2. 在遞交選舉郵件樣本時，候選人須選定在下列一間香港郵政的郵政局投寄：
 When handing in the specimens of election mail, candidates must select **one** of the following post offices of Hongkong Post where they intend to make their postings:

- 投寄時間：由提名期開始（即 2017 年 2 月 14 日開始）的辦公時間（星期日及公眾假期除外）

Posting period: During office hours starting from Nomination Period (i.e. starting from 14 February 2017) (excluding Sunday and public holiday)

郵政局 Post Office	地址 Address	電話 Telephone
郵件處理中心 Mail Processing Centre		
中央郵件中心大量郵件投寄櫃位 Bulk Mail Acceptance Counter of Central Mail Centre	九龍灣宏展街 1 號中央郵件中心地下大量郵件投寄櫃位 Bulk Mail Acceptance Counter, G/F, Central Mail Centre, 1 Wang Chin Street, Kowloon Bay	2908 0025
香港區 Hong Kong		
郵政總局 General Post Office	中環康樂廣場 2 號 2 Connaught Place, Central	2921 2332 2921 2337